

FEMALE END VIEW

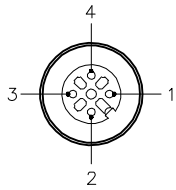

SPECIFICATIONS

| | |
|-----------------------------|----------------------------------|
| HOUSING MATERIAL/PLATING | NYLON/BLACK |
| CONTACT MATERIAL/PLATING | BRASS/GOLD |
| COUPLING NUT MATERIAL/COLOR | NYLON/BLACK |
| RATED CURRENT [A] | 4.0 A |
| RATED VOLTAGE [V] | 250 V |
| MAXIMUM WIRE SIZE | 18 AWG |
| CABLE GRIP RANGE | 4-6mm |
| TEMPERATURE RATING | -40°C to +85°C (-40°F to +185°F) |
| PROTECTION CLASS | IEC IP67 |
| TERMINATION TYPE | SCREW TERMINAL |

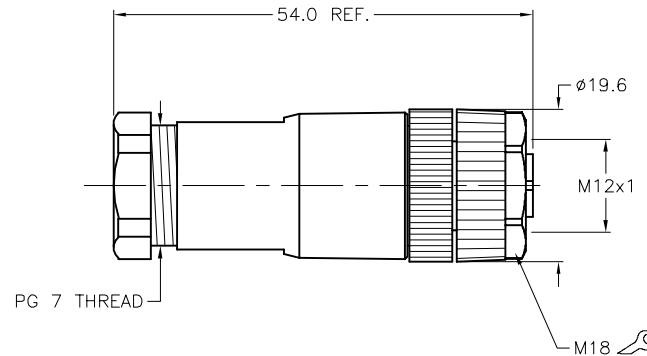

SOURCE DRAWING - FOR REFERENCE ONLY

| | | | | | | | |
|------------------------------------|---------------------------------|---|----------|--|-------------|--|--|
| RELATED DOCUMENTS | | 3RD ANGLE PROJECTION | | THIS DRAWING IS CONFIDENTIAL AND THE PROPERTY OF TURCK INC. USE OF THIS DOCUMENT WITHOUT WRITTEN PERMISSION IS PROHIBITED. | | 3000 CAMPUS DRIVE MINNEAPOLIS, MN 55441 1-800-544-7769 (763) 553-7300 (763) 553-0708 fax www.turck.us | |
| 1. 2. 3. 4. | | | | DRFT JMS DATE 10/09/95 APVD SCALE 1=1.0 | | DESCRIPTION B 8141-0 | |
| MATERIAL SEE SPECIFICATIONS | | ALL DIMENSIONS DISPLAYED ON THIS DRAWING ARE FOR REFERENCE ONLY | | UNIT OF MEASUREMENT MILLIMETERS | | IDENTIFICATION NO. U6545 | |
| FINISH SEE SPECIFICATIONS | | CONTACT TURCK FOR MORE INFORMATION | | DO NOT SCALE THIS DRAWING | | REV D | |
| D | UPDATED LOWER TEMPERATURE RANGE | ER | 09/27/18 | 66837 | | | |
| REV | DESCRIPTION | BY | DATE | ECO NO. | FILE: U6545 | SHEET 1 OF 1 | |